

Cabin HOSPITAIR® - 15 bar

Lubricated screw technology



Outdoor cabin

- Also available in 11 bar configuration
- Medicinal air plants with lubricated screw compressors
- Cabin for outdoor installation
- Fit to EN ISO 7396-1 standard and HTM BS
- Air treatment system with 2 adsorption air dryers SEC 7HC type
- Air quality complying with European pharmacopoeia
- Receiver(s) installed inside the cabin
- Integrated network alarm
- Simplified setting and ready-to-run plants



Cabin made of composites panels

Characteristics

HOSPITAIR® C 15 bar	Power kW 50/ 60 Hz	Flow rate* m ³ .h ⁻¹		Air dryer type	Receiver - l		Noise level dB(A)**
		at 50 Hz	at 60 Hz		1 line	2 lines	
MVX4	4	22	22	AD5035	500	2 x 500	57
MVX5	5,5	32	32	AD5035	500	2 x 500	57
MVA9	7,5	50	50	AD5065	500	2 x 500	58
MVB12	11	78	78	AD5065	500	2 x 500	58
MVB16	15	102	106	AD5130	500	2 x 500	62
MVC19	18,5	150	144	AD5195	500	2 x 500	62
MVC23	22	174	170	AD5195	500	2 x 500	63

* Compressor flow rate further to ISO 1217 : 1996 - C Annex / ** Noise level further to PN8 NTC 2.3, measured one meter away in free area

Process sequence (ex : duplex plant)

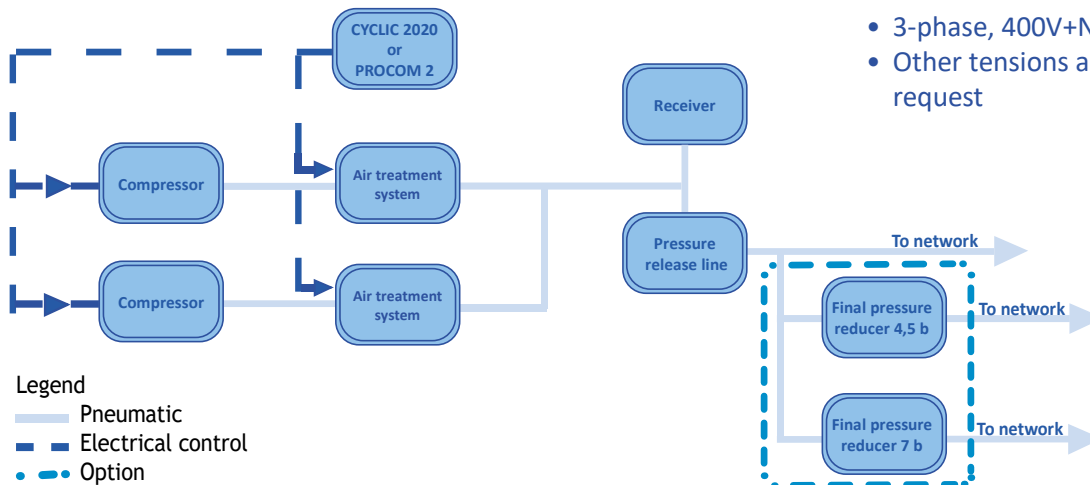

Power supply

- 3-phase, 400V+N+E / 50Hz (standard)
- Other tensions and frequencies on request



Range complying with 93/42/CEE directive



Range complying with 97/23/CE directive

Available set-up

	1 production assembly	2 production assemblies
PROCOM 2	■	■
CYCLIC 2020	■	■
Single pressure release line	■	◆
Duplex parallel pressure release line	◆	■
Hygrometer	■	■
Network alarm	■	■
Oil-water separator	■	■
CO monitoring	◆	◆

■ Standard equipment ◆ Optional equipment



Medicinal air plants

Lubricated screw compressor



Dimensions (mm)

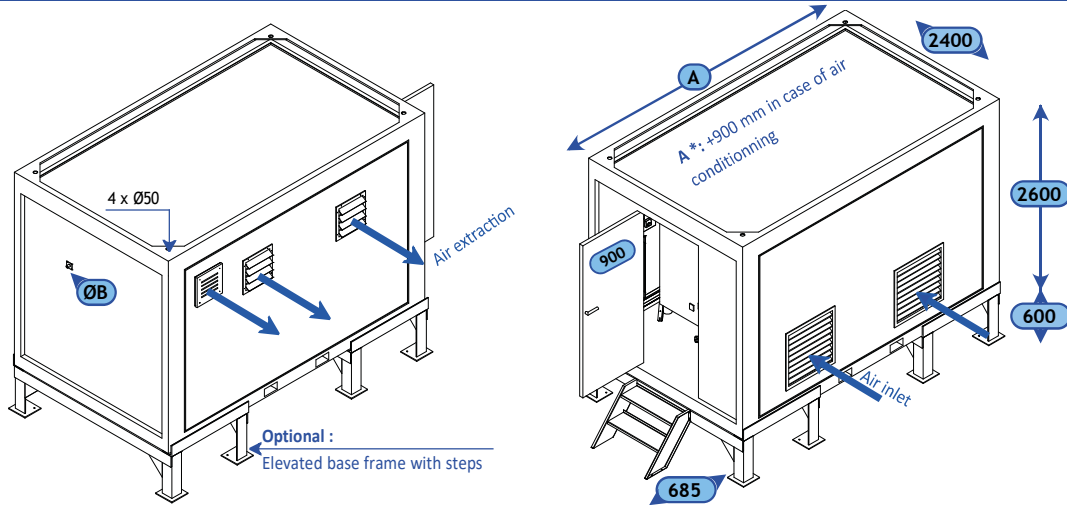

	HOSPITAIR C with 1 compressor			HOSPITAIR C with 2 compressors		
	A*	Ø B	Weight kg	A*	Ø B	Weight kg
MVX4	2200	1/2"	1050	3500	3/4"	1800
MVX5	2200	1/2"	1070	3500	3/4"	1880
MVA9	2200	1/2"	1100	4000	3/4"	2010
MVB12	2500	1/2"	1300	4000	3/4"	2300
MVB16	2500	3/4"	1600	4000	3/4"	2600
MVC19	2700	3/4"	1670	4300	3/4"	2750
MVC23	3000	3/4"	1950	4300	3/4"	3290

Plant references

HOSPITAIR® CABIN 15 bar			MVX4	MVX5	MVA9	MVB12	MVB16	MVC19	MVC23
Hospitair C1	Cyclic 2020	1 compressor	921003	921004	924922	921006	921007	921008	921009
Hospitair C2	Cyclic 2020	2 compressors	921017	921018	924923	923515	923516	921022	921023
Hospitair C2	Cyclic 2020	2 compressors + air conditioning	922347	922348	924924	922350	922351	922352	922353
Hospitair C1	Procom 2	1 compressor	924303	924304	924925	924306	924307	924308	924309
Hospitair C2	Procom 2	2 compressors	921010	921011	924926	923514	921014	921015	921016
Hospitair C2	Procom 2	2 compressors + air conditioning	924258	924259	924927	924261	924262	924263	924264

SEC 7HC

Air treatment device included

CY10-PF36-SUB36
AD5035/CHA36

CY20-PF72-SUB72
AD5065/CHA72

CY20-PF109-SUB109
AD5130/CHA109

CY30-PF/
SUB217
AD5195-
CHA217

PRESSURE RELEASE LINE	cabin with 1 compressor	DP36S	DP72S	DP109S	DP36S
	cabin with 2 compressors	DP72DP	DP144DP	DP218DP	
OIL-WATER SEPARATOR integrated		OWAMAT 10	OWAMAT 11	OWAMAT 12	

Accessories and option references

	MVX4	MVX5	MVA9	MVB12	MVB16	MVC19	MVC23
ELEVATED BASE FRAME with steps	621410						
Report Status with CYCLIC 2020 *	621410			621411			
Report Status with PROCOM 2 *	12 first alarms		614079	12 following alarms		622463	
CO monitoring	CYCLIC 2020		724915	PROCOM 2		724912	

* Do not forget to order electrical cord 615892 x 3 (see p 83)

Specifications are subject to be changed without notice